

MICROCIRCUIT FOR DIGITAL MEDICAL THERMOMETER

(Functional Analogue of JTGP71AS by Company "Toshiba")

Microcircuit IZ8071 is intended for measurement of the body temperature within the range from plus 32,0 to plus 42,0 °C (from plus 89,6 to plus 107,6 °F). The thermometer microcircuit includes the oscillator circuit for the thermoresistor, the system oscillator circuit, LCD driver, the circuit of the sound signal (sound emitting piezoelement), double wire interface circuit and EEPROM.

Main characteristics:

- Range of the measured temperatures from plus 32 to plus 42 °C (from plus 89,6 to plus 107,6 °F);
- Accuracy of the temperature measurement
 - For the range from plus 35 to plus 38 °C - $\pm 0,05$ °C;
 - For the ranges from plus 32 to plus 35 °C and from plus 38 to plus 42 °C - $\pm 0,1$ °C;
 - For the range from plus 32 to plus 42 °C - $\pm 0,1$ °C.
- resolution 0,0025 °C;
- method of temperature measurement – bit-linear approximation;
- LCD driver circuit 3COM x 11SEG;
- voltage doubler circuit with the operating frequency of 8 kHz;
- sound piezoelement driver (connected to the supply source U_{DD2});
- supply voltage range U_{DD} from 1,2 to 1,65 V;
- operation from the battery supply source from $U_{DD} = 1,5$ V, type of cell LR41;
- identification circuit of the cell discharge BLD (identification voltage 1,34 V);
- detector circuit of the cell installation (generates the internal reset signal);
- capacity of the embedded EEPROM 120 bits, from them:
 - 88 bits – division ratio;
 - 16 bits – compensation;
 - 4 bits – adjustment of BLD;
 - 5 bits – adjustment of the system frequency;
 - 3 bits – convergence time;
 - 1 bit – initial measurement unit;
 - 1 bit – change denial of measurement units;
 - 1 bit – indication of the previous measured value;
 - 1 bit – selection of the number of signs after point.
- voltage for programming EEPROM (data write voltage) from 15,5 to 16,5 V;
- data storage time in EEPROM with the turned off supply - 10 years;
- number of cycles of EEPROM erase / write – 10000;
- embedded RC-oscillator with its own frequency 32,32 kHz with the adjustment function (external resistance);
- double wire serial interface ensures EEPROM read-out / write, temperature data read-out (15 bits, always °C, resolution 0,0025 °C);
- application of the temperature measurement values via the serial interface;
- function for storing the maximum measured temperature;
- switch-on of the low power consumption via «SW» - terminal;
- function of the automatic switch-off (after 30 minutes), transition into the low power consumption mode.



Table 1 – Purpose of Contact Pads

Number of Contact Pad	Identification	Purpose
01	V _{DD}	Supply pin from voltage source +1,5 V
02	T1	Test input
03	T2	Test input
04	HV	Pin for programming EEPROM
05	T4	Test input
06	RSYS1	Input of cycle RC-oscillator
07	T5	Test input
08	RSYS2	Output of the cycle RC-oscillator
09	T6	Test output
10	SYCK	Output of internal frequency
11	T7	Test output
12	SCK	Synchronization output of the serial port
13	DATA	Data input / output of the serial port
14	BRESET	Input of common reset
15	MODE	Activation input of the serial port
16	SW	Control input
17	COM3	Control output of the LCD common electrode
18	COM2	Control output of the LCD common electrode
19	COM1	Control output of the LCD common electrode
20	SEG11	Control output of the LCD sign electrode
21	SEG10	Control output of the LCD sign electrode
22	SEG9	Control output of the LCD sign electrode
23	SEG8	Control output of the LCD sign electrode
24	SEG7	Control output of the LCD sign electrode
25	SEG6	Control output of the LCD sign electrode
26	SEG5	Control output of the LCD sign electrode
27	SEG4	Control output of the LCD sign electrode
28	SEG3	Control output of the LCD sign electrode
29	SEG2	Control output of the LCD sign electrode
30	SEG1	Control output of the LCD sign electrode
31	C2	Capacitance connection pin of the voltage doubler
32	C1	Capacitance connection pin of the voltage doubler
33	V _{DD2}	Double supply pin +3,0 V
34	BZ1	Control output of the sound signal
35	BZ2	Control output of the sound signal
36	VBGR	Reference voltage output
37	T3	Test input
38	RS	Output of the measuring RC-oscillator
39	RF	Output of the measuring RC-oscillator
40	SC	Input of the measuring RC-oscillator
41	V _{SS}	Common pin
42	TEST	Test mode setting input

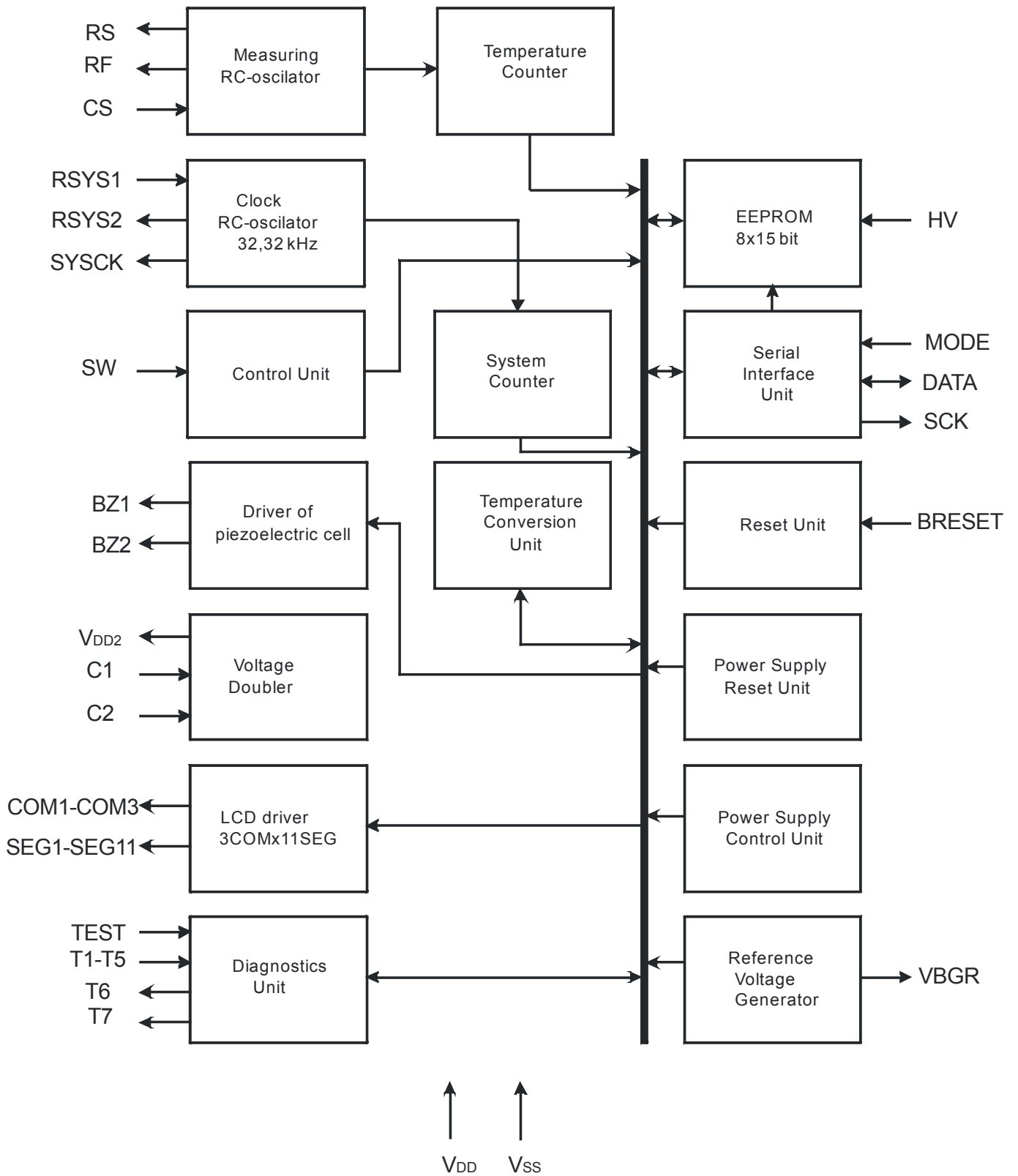

Figure 1 – Layout diagram

Table 2 – Recommended operating modes

Symbol	Parameter	Norm		Unit
		Min	Max	
U_{DD}	Supply voltage	1,2	1,65	V
U_{DD2}	Voltage at voltage doubler	2,4	3,3	V
U_{IN}	Input voltage	0	U_{DD}	V
U_{ILSW}	Low level input voltage at the pin SW	0	$0,2U_{DD}$	V
U_{IHSW}	High level input voltage at the pin SW	$0,8U_{DD}$	U_{DD}	V
T_A	Ambient operating temperature	-10	60	°C

Table 3 – Absolute maximum ratings

Symbol	Parameter	Norm		Unit
		Min	Max	
U_{DD}	Supply voltage	-0,2	2,0	V
U_{DD2}	Voltage at the voltage doubler	-0,2	4,0	V
U_{IN}	Input voltage	-0,2	$U_{DD} + 0,2$	V
U_{ILSW}	Low level input voltage at the pin SW	-0,2	-	V
U_{IHSW}	High level input voltage at the pin SW	-	$U_{DD} + 0,2$	V
T_{STG}	Storage temperature	-40	125	°C

Table 4 – Microcircuit Electric Parameters at T_A from minus 40 to plus 85 °C

Symbol	Parameter	Measurement mode	Norm		Ambient Temperature, °C	Unit
			Min	Max		
I _{ILSW}	Low level input current at pin SW	U _{DD} = 1,5 V, U _{DD2} = 3,0 V, U _{IN} = 0 V	$\frac{53,5}{20}$	$\frac{125}{150}$	25 ± 10 -10, 60	uA
I _{IL}	Low level input current at pins MODE, BRESET	U _{DD} = 1,5 V, U _{DD2} = 3,0 V, U _{IN} = 0 V	$\frac{53,5}{20}$	$\frac{125}{150}$		uA
I _{IH}	High level input current at pins TEST, T1-T5	U _{DD} = 1,5 V, U _{DD2} = 3,0 V, U _O = 1,5 V	$\frac{1,0}{0,8}$	$\frac{100}{125}$		uA
U _{DD2}	Output voltage of voltage doubler	U _{DD} = 1,5 V	$\frac{2,4}{2,3}$	$\frac{3,3}{3,4}$		V
I _{OHCOM}	High level output current at pins COM1-COM3	U _{DD} = 1,5 V, U _{DD2} = 3,0 V, U _O = 2,8 V	$\frac{4,0}{3,0}$	-		uA
I _{OLCOM}	Low level output current at pins COM1-COM3	U _{DD} = 1,5 V, U _{DD2} = 3,0 V, U _O = 0,2 V	$\frac{4,0}{3,0}$	-		uA
I _{OMH}	Middle level output current at pins COM1-COM3	U _{DD} = 1,5 V, U _{DD2} = 3,0 V, U _O = 1,75 V	$\frac{4,0}{3,0}$	-		uA
I _{OML}		U _{DD} = 1,5 V, U _{DD2} = 3,0 V, U _O = 1,35 V	$\frac{4,0}{3,0}$	-		uA
I _{OHSEG}	High level output current at pins SEG1-SEG11	U _{DD} = 1,5 V, U _{DD2} = 3,0 V, U _O = 2,8 V	$\frac{0,4}{0,3}$	-		uA
I _{OLSEG}	Low level output current at pins SEG1-SEG11	U _{DD} = 1,5 V, U _{DD2} = 3,0 V, U _O = 0,2 V	$\frac{0,4}{0,3}$	-		uA
I _{OHBZ}	High level output current at pins BZ1, BZ2	U _{DD} = 1,2 V, U _{DD2} = 2,4 V, U _O = U _{DD2} - 0,5 V	$\frac{1,0}{0,4}$	-		mA
I _{OLBZ}	Low level output current at pins BZ1, BZ2	U _{DD} = 1,2 V, U _{DD2} = 2,4 V, U _O = 0,5 V	$\frac{1,0}{0,4}$	-		mA
I _{ZL}	Leakage current at pins SC, RS, RF	U _{DD} = 1,65 V, U _{DD2} = 3,3 V, U _O = 0,5 V	-	$\frac{0,1}{0,15}$		uA
I _{OP}	Consumption current in the temperature measurement mode	U _{DD} = 1,65 V, LCD is on, pins SCK, DATA are off, pins BZ1, BZ2 are off, R _S = (29 – 31) kΩ, C _S = 680 pF ± 5 %	-	$\frac{50}{75}$		uA
I _{DDOFF}	Consumption current in the mode «Off»	U _{DD} = 1,65 V, R _S = (29 - 31) kΩ, C _S = 680 pF ± 5 %	-	$\frac{0,3}{0,9}$		25 ± 10 -10, 60
I _{DDOFF2}		U _{DD} = 1,65 V, R _S = (29 – 31) kΩ, C _S = 680 pF ± 5 %	-	0,5	40	

Table 4 Continued

Symbol	Parameter	Measurement Mode	Norm		Ambient Temperature, °C	Unit
			Min	Max		
F _{SYS}	Frequency of the cycle RC-oscillator	U _{DD} = 1,5 V, R _X = 590 kΩ ± 5 %	25,86	38,78	25 ± 10	kHz
F _{SYSVT}		U _{DD} = 1,28; 1,65 V, R _X = 590 kΩ ± 5 %	22,75	43,43	10, 40	
U _{REF}	Reference voltage	Before fine tuning, U _{DD} = 1,34 V	1,125	1,310	25 ± 10	V
		After fine tuning, U _{DD} = 1,34 V	1,200	1,250	10, 40	
		After fine tuning, U _{DD} = 1,34 V	1,165	1,275		
U _{PF}	Actuation voltage of the supply disrapture sensor	After fine tuning, U _{DD} = 1,29 V and U _{DD} = 1,39 V	1,29	1,39	25 ± 10	V
		After fine tuning, U _{DD} = 1,28 V and U _{DD} = 1,4 V	1,28	1,4	10, 40	
A _T	Temperature measurement accuracy: For the range from plus 35 to plus 38 °C For the ranges from plus 32 to plus 35 °C and from plus 38 to plus 42 °C	U _{DD} = 1,5 V U _{DD2} = 3,0 V	-0,05	0,05	25 ± 10	°C
			-0,1	0,1		

Notes

- 1 R_S – resistor, connected to the pin RS.
- 2 R_X - resistor, connected between the pins RSYS1 and RSYS2.
- 3 C_S – capacitor, connected to the pin CS



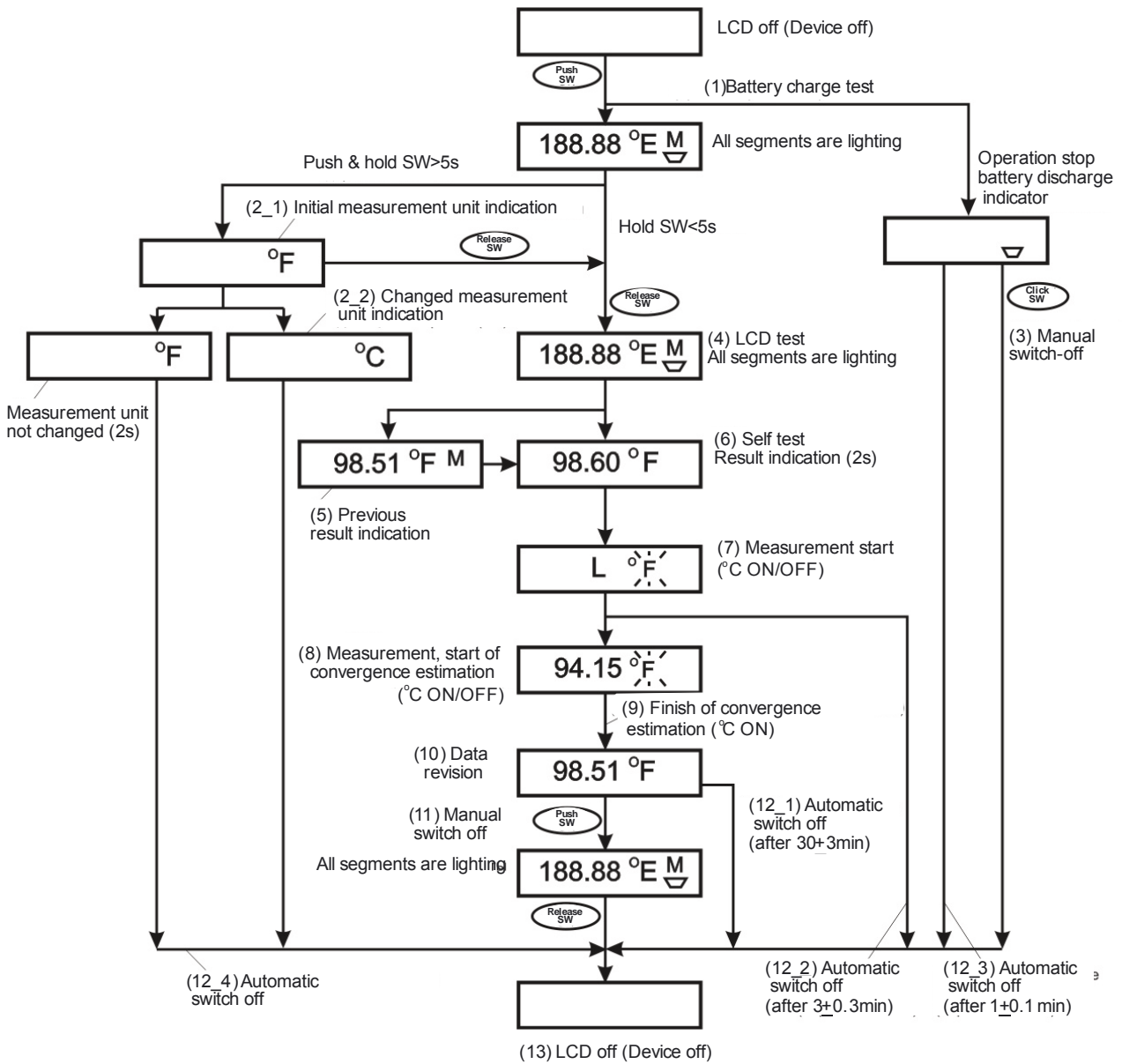

Figure 3 – Operational algorithm of the microcircuit in the mode of Farenheit degrees (°F)

Operational modes of thermometer

(1) - Battery charge test . Battery voltage (BLD) is tested immediately after IC turns on. Display indicates symbol of discharged battery if battery voltage less than BLD value, in that case temperature measurement is not processed. IC turns off automatically after 1 minute or by pressing of "SW" button (3).

(2) - Change of measurement unit. At the turned off thermometer on pressing of button "SW" and holding more than 5 seconds the microcircuit should turn to measurement unit change mode. LCD will display an initial measurement unit (2_1). At holding of button "SW" more than 2 seconds the unit will be changed, else (holding less than 2 seconds) IC turn to «totally on» mode - all LCD segments will light up. After measurement unit changed IC turns off after 2 seconds automatically. If the EEPROM bit "PROHI" is equal «1» measurement unit does not change.

(4) – LCD test. At the turned on thermometer on pressing of button "SW" LCD test is processed during 2 seconds all LCD segments are light up («totally on» mode). If "DIGIT4" bit is equal «0» segments of the second after a point digit are not displayed.

(5) - Previous value display. Within two seconds LCD displays previous measurement result, measurement units of and a symbol "M". The result of the previous measurement will be lost after replacement of a battery or measurement unit change. In this case LCD displays symbol "M" and measurement unit. If "NONPREV" bit is equal "1" the result of the previous measurement is not displayed.

(6) - Self-diagnostics, result display. Self-diagnostics is carried out at each turn on of the thermometer to provide control of functioning of the device. If the thermometer operates normally LCD displays the temperature (37,00±0,05) °C or (98,60±0,09) °F in 2 seconds. At one digit after point it is displayed (37,0±0,1) °C or (98,6±0,2) °F.

(7) - Measurement Start. Temperature measurement is carried out after self-diagnostics. On result of measurement is displayed on LCD. Symbol °C / ° F blinks (1Hz, duty factor is equal 1/2). An estimation of temperature convergence also starts after self-diagnostics.

(8) – Measurement, start of estimation of convergence. Symbol °C / ° F continues blink during measurement process. Value displayed on LCD changes with temperature rise. LCD always displays maximum temperature.

At measurement unit °C:

- | | |
|-------------------------|----------------------|
| - below 32°C | - L °C; |
| - for range 32 ... 42°C | - measured value °C; |
| - above 42°C | - H °C. |

At measurement unit °F:

- | | |
|------------------------------|----------------------|
| - below 89,6°F | - L °F; |
| - for range 89,6 ... 107,6°F | - measured value °F; |
| - above 107,6°F | - H °F. |

Estimation of convergence starts if measured temperature is above 32°C (89,6°F) and temperature change not rather 0,005 °C per 2 seconds. Measurement stops 20 minutes before device turns off if device fixes "H" (high temperature).

(9) – Completion of measurement. Symbol °C / ° F stop blinking (displayed constantly) if temperature rise rate becomes equal 0,005 °C per 2 seconds (convergence time is not programmed). Sound signal is generated after temperature measurement completed. Temperature measurement renews after signal termination

(10) - Data revision. In the event that the temperature continues to raise, even after operation of measurement of temperature is completed, data are revised, and LCD always displays the maximum temperature. After the termination of measurement of temperature the unit of measure on the display does not blink, and displays constantly.

(3), (11) - Manual switching-off. Pressing of the ON/OFF button switches off the device, being in any of states (4) - (10). After button pressed device generates sound signal.



(12_1), (12_2), (12_3), (12_4) - Automatic switching-off.

(12_1) – Device is automatically switched-off through (30 ± 3) minutes after switching-on.

(12_2) - Device is automatically switched-off, if $^{\circ}\text{C} / ^{\circ}\text{F}$ is displayed on LCD more than $(3 \pm 0,3)$ minutes after the measurement start.

(12_3) - Device is automatically switched-off through $(1 \pm 0,1)$ minute after “Low battery” symbol displayed.

(12_4) - Device is automatically switched-off the after measurement unit changed.

If after display of a symbol of the category of a battery to press button "SW" the device is disconnected at once (without a sound signal).



Application diagram and LCD format

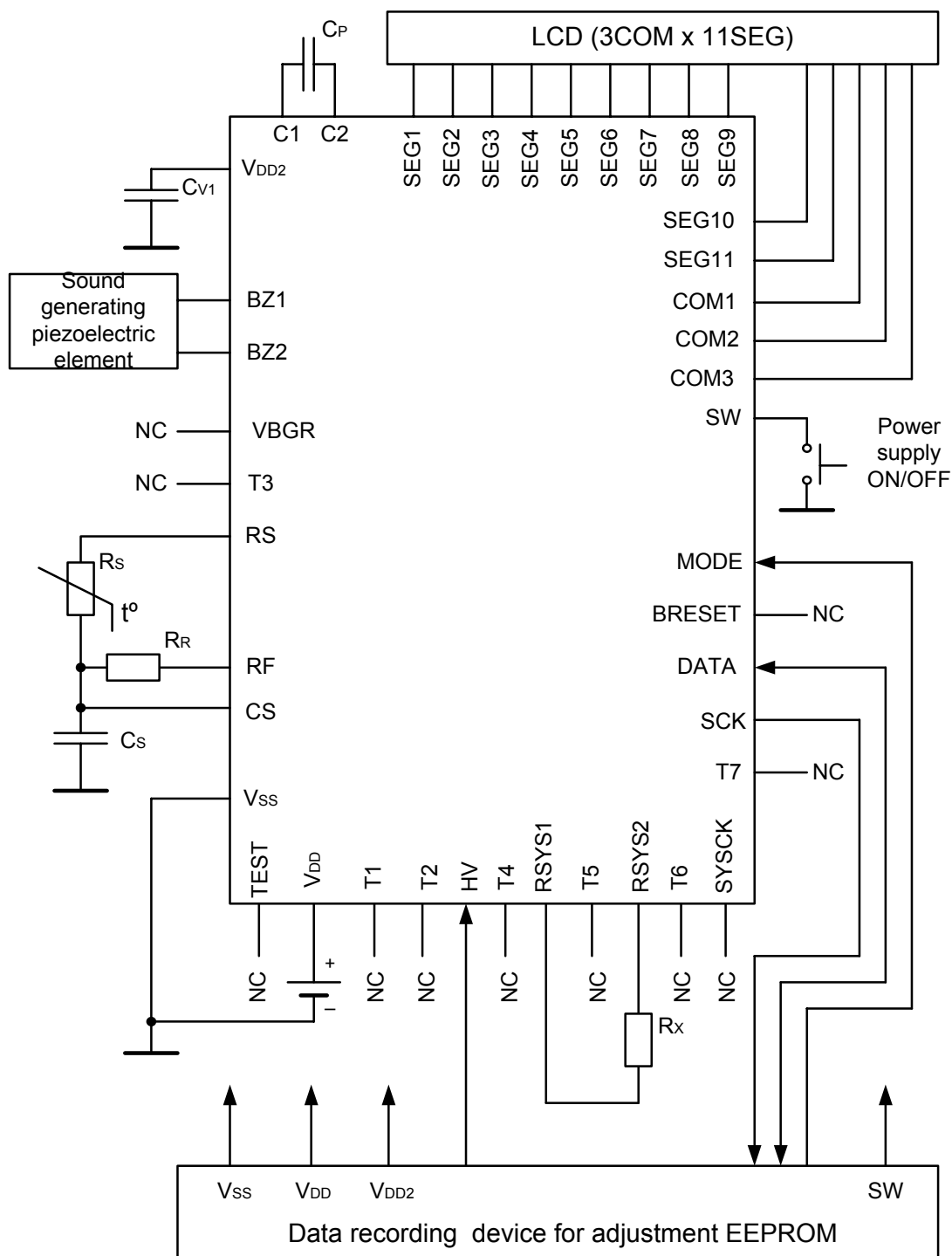

- C_S – capacitor C= 680 pF ± 5 %
- C_{V1} - capacitor C= 1 uF ± 10 %
- C_P – capacitor C= 1 uF ± 10 %
- R_S – thermoresistor SEMITEC 503ET-3H «Ishizuka Electronics Corp»
- R_R – resistor R = 30 kΩ ± 0,5 %
- R_X - resistor R = 590 kΩ ± 1 %

Fig. 4 – Recommended application circuit

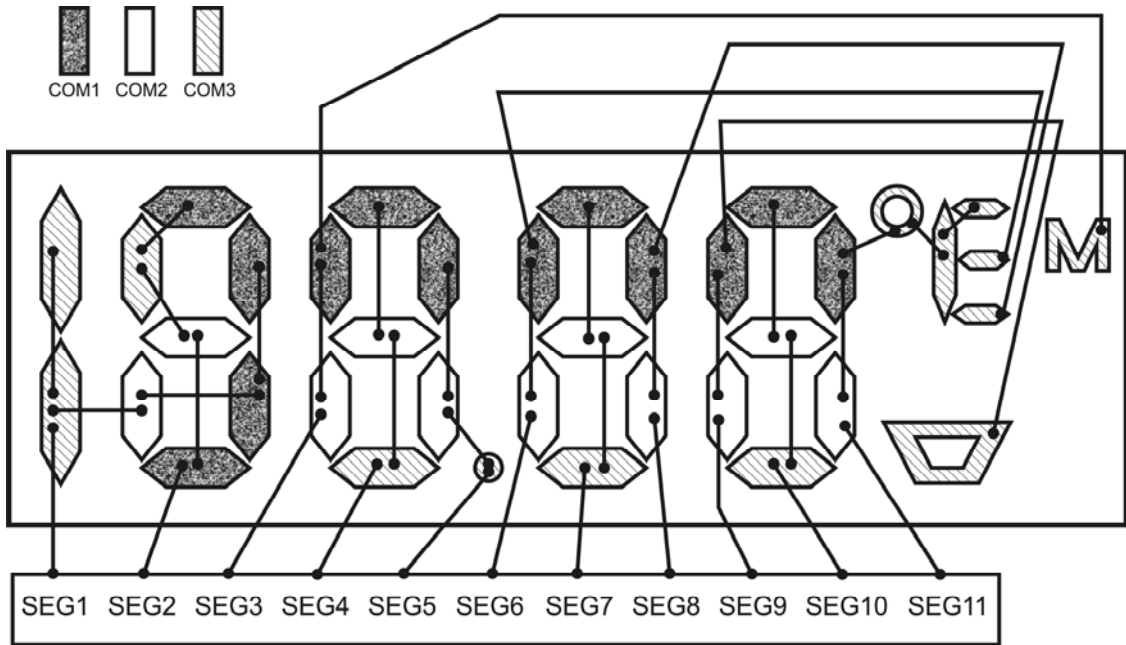

Fig. 5 – LCD format

Serial interface , EEPROM read/write operations, temperature reading

Serial interface

Data exchange serial interface is purposed for data reading and writing to IC.

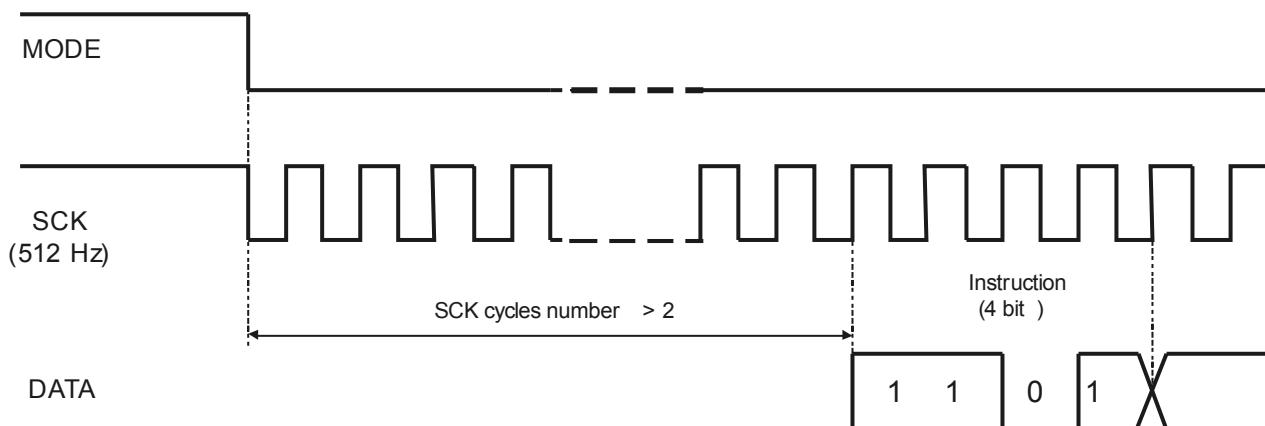

Fig. 6 – Time diagram of instruction loading via serial; interface

SCK frequency is equal to $F_{SYS} / \text{division factor}$, that is ~512 Hz. Buyer can change the division factor. During first and second SCK cycles “DATA” pin should be “0”.

Table 5 – Serial interface control instruction

Instruction code				Operation	EEPROM state
C3	C2	C1	C0		
1	1	1	1	No	STANDBY
1	1	1	0	Read EEPROM	READ
1	1	0	1	Write EEPROM	ERASE / WRITE
1	1	0	0	Measuring counter output	STANDBY

If high high order bits C3, C2 set «1», data reading erasing/writing is processed (depends on bits C1, C0 content).

Data writing to EEPROM

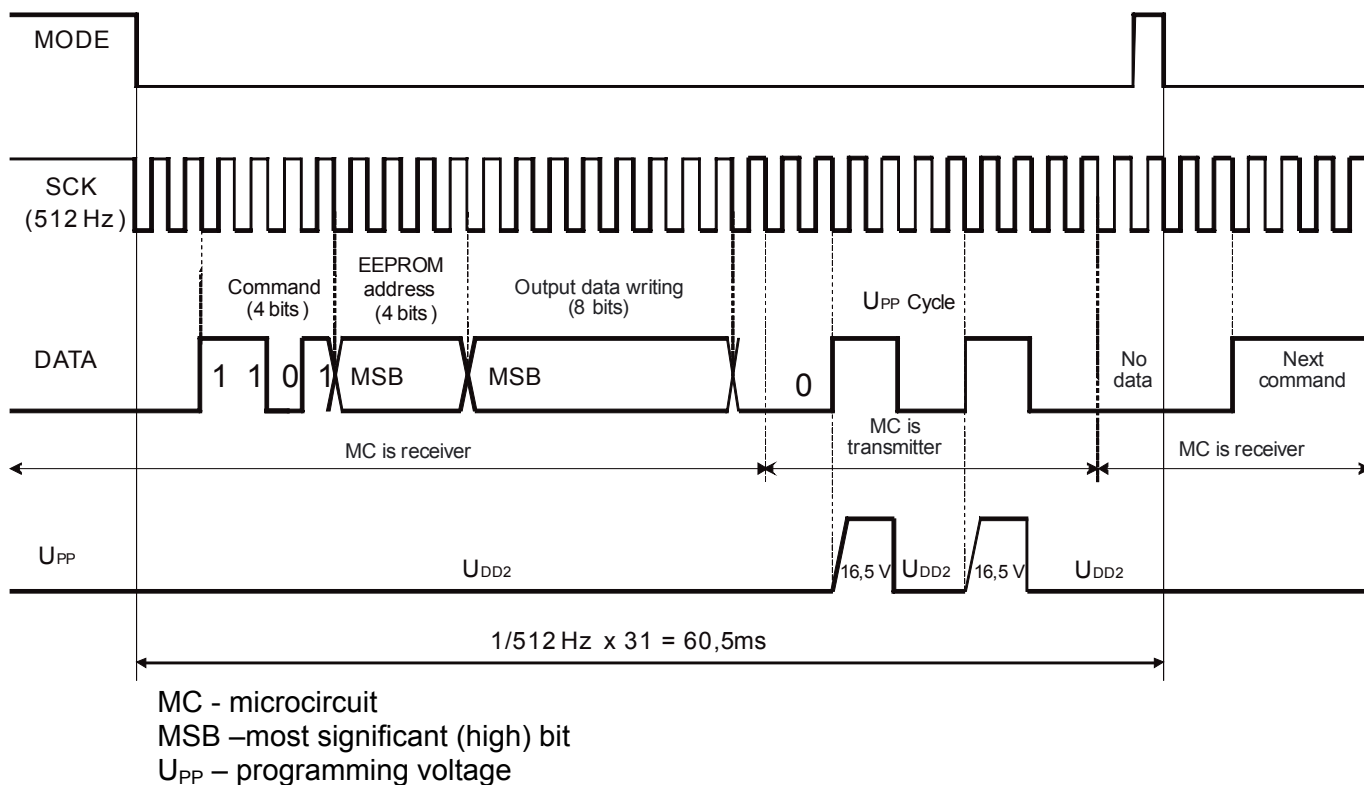

Fig. 7 – Time diagram of data writing to EEPROM through the serial interface

Data reading from EEPROM

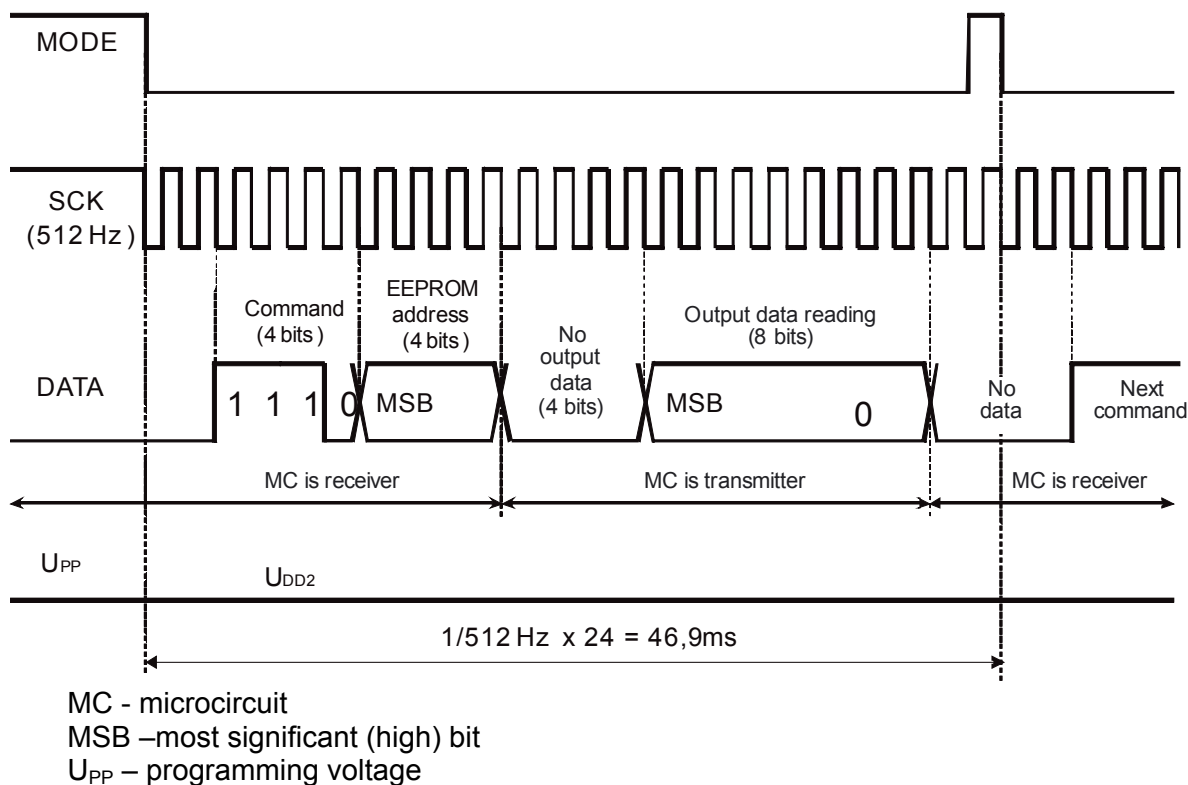

Fig. 8 – Time diagram of data reading from EEPROM through the serial interface

Temperature reading

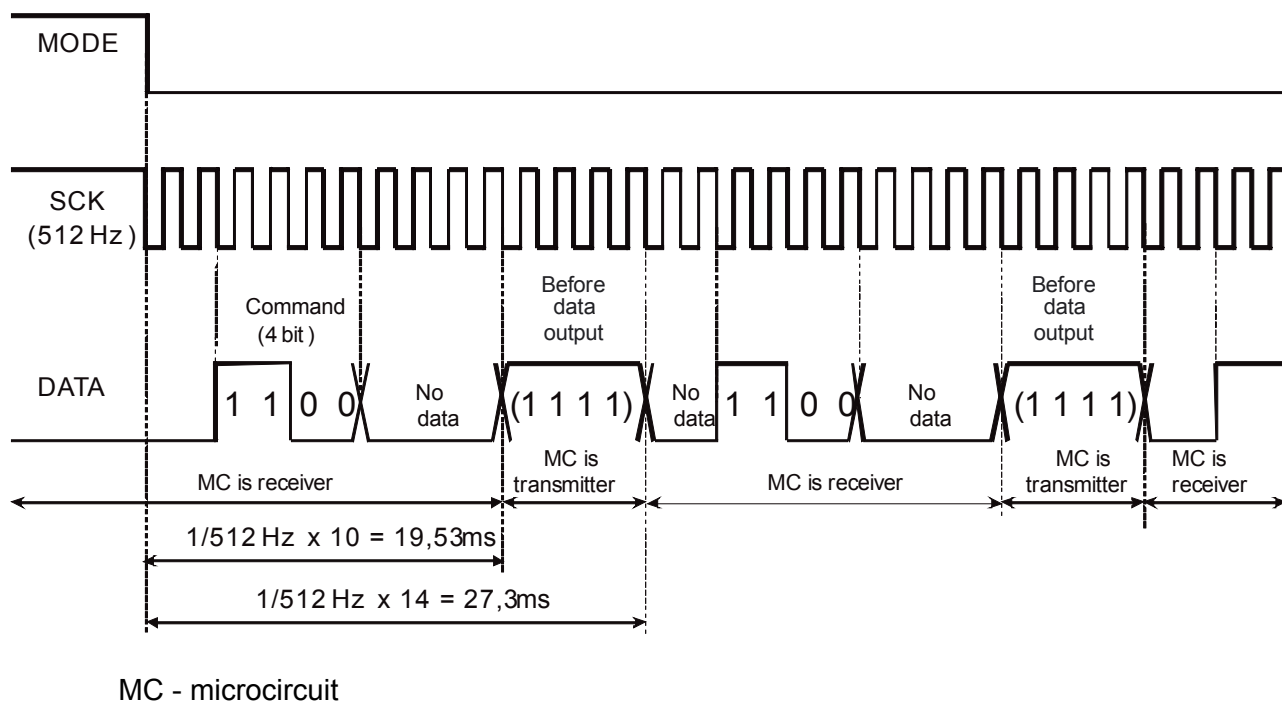

Fig.9 – Time diagram of measured temperature reading

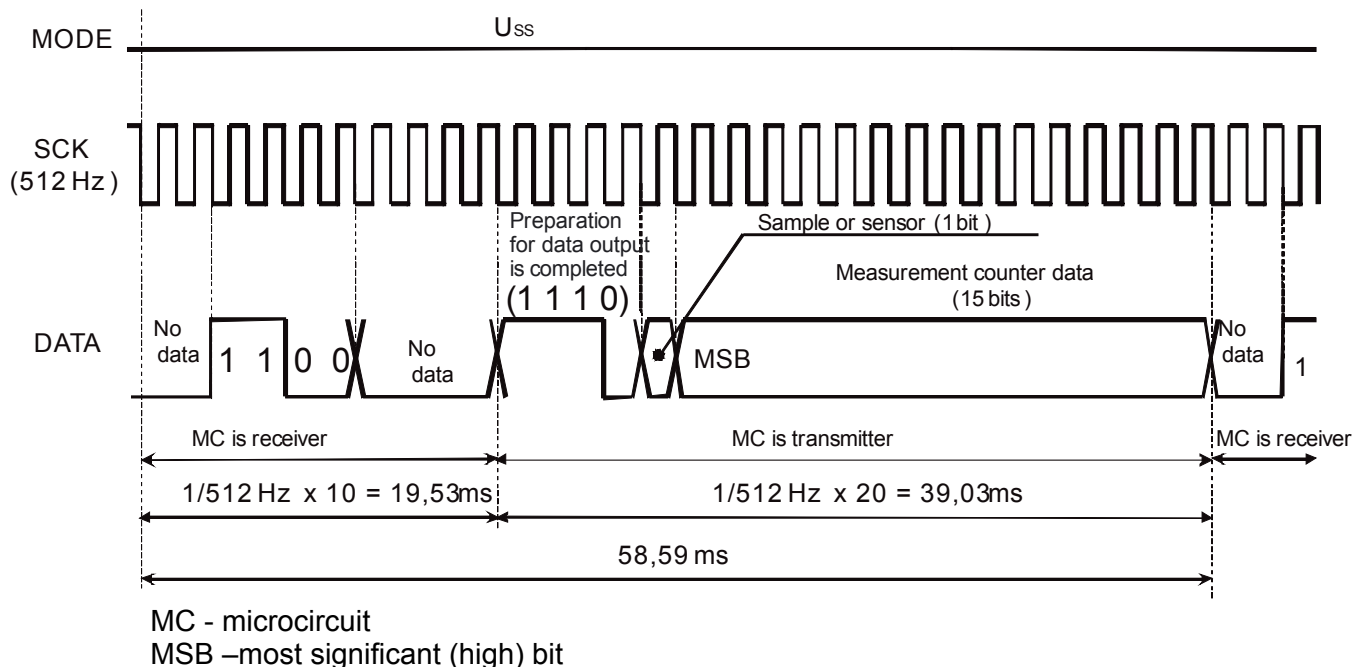

Fig.10 – Time diagram of temperature measurement result return through the serial interface

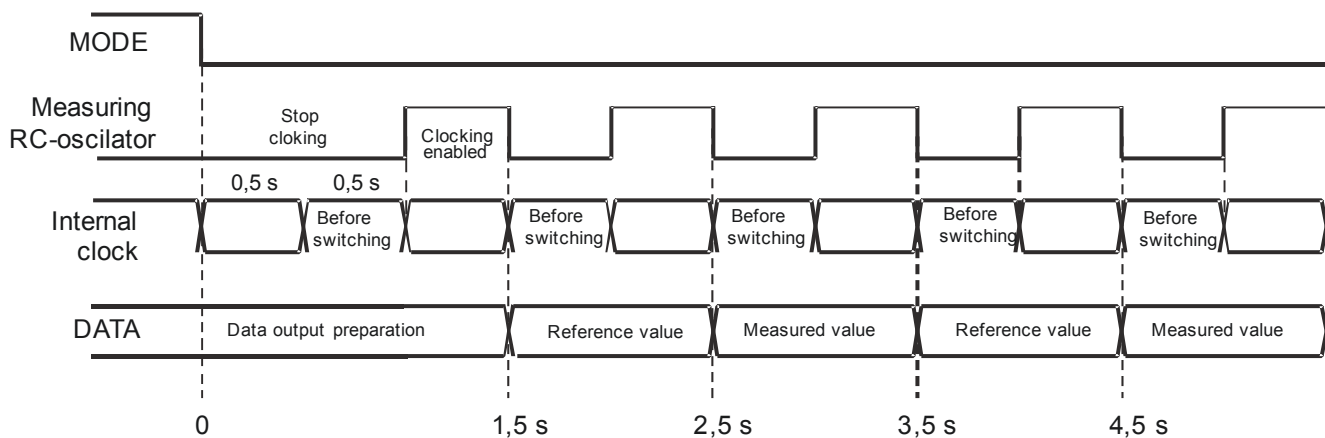

Fig 11 – Temperature reading time diagram

It takes about 1,5 sec after MODE pin set “0” and instruction “1100” to switch ICs to the state “Data output preparation completed”. After that IC stays in this mode and next instructions “1100” will be ignored.

Switching of IC out the state “Data output preparation completed” is possible by following ways:

- MODE pin switching – «0» → «1» → «0»;
- SW pin switching- «1» → «0» → «1» .

Measurement unit is °C always (not depends on operation mode of the thermometers). Temperature data output processed in binary decimal code (BCD)

Table 6 – Data output format

Bit15	Bit 14	Bit 13 – 10	Bit 9 – 6	Bit 5 – 2	Bit 1 – 0
Data type					
1 – reference value	0 – “3x.xxxx °C”	0000 – “x0.xxxx °C”	0000 – “xx.0xxx °C”	0000 – “xx.x0xx °C”	00 – “xx.xx00°C”
0 – measured value	1 – “4x.xxxx °C”	... 1001 – “x9.xxxx °C”	... 1001 – “xx.9xxx °C”	... 1001 – “xx.x9xx °C”	01 – “xx.xx25°C” 10 – “xx.xx50°C” 11 – “xx.xx75°C”



Programming function

Table 7 – EEPROM memory map

EEPROM address, ADR[3:0]	EEPROM data, D[7:0]							
	Bit 7	Bit 6	Bit 5	Bit 4	Bit 3	Bit 2	Bit 1	Bit 0
1110	C0[7]	C0[6]	C0[5]	C0[4]	C0[3]	C0[2]	C0[1]	C0[0]
1101	C10[7]	C10[6]	C10[5]	C10[4]	C10[3]	C10[2]	C10[1]	C10[0]
1100	C9[7]	C9[6]	C9[5]	C9[4]	C9[3]	C9[2]	C9[1]	C9[0]
1011	C8[7]	C8[6]	C8[5]	C8[4]	C8[3]	C8[2]	C8[1]	C8[0]
1010	C7[7]	C7[6]	C7[5]	C7[4]	C7[3]	C7[2]	C7[1]	C7[0]
1001	C6[7]	C6[6]	C6[5]	C6[4]	C6[3]	C6[2]	C6[1]	C6[0]
1000	C5[7]	C5[6]	C5[5]	C5[4]	C5[3]	C5[2]	C5[1]	C5[0]
0111	C4[7]	C4[6]	C4[5]	C4[4]	C4[3]	C4[2]	C4[1]	C4[0]
0110	C3[7]	C3[6]	C3[5]	C3[4]	C3[3]	C3[2]	C3[1]	C3[0]
0101	C2[7]	C2[6]	C2[5]	C2[4]	C2[3]	C2[2]	C2[1]	C2[0]
0100	C1[7]	C1[6]	C1[5]	C1[4]	C1[3]	C1[2]	C1[1]	C1[0]
0011	IVTC3[3]	IVTC3[2]	IVTC3[1]	IVTC3[0]	IVTC2[3]	IVTC2[2]	IVTC2[1]	IVTC2[0]
0010	Not used	Not used	IVTC1[3]	IVTC1[2]	IVTC1[1]	IVTC1[0]	IVTC0[1]	IVTC0[0]
0001	TRFSYS[4]	TRFSYS[3]	TRFSYS[2]	TRFSYS[1]	TRFSYS[0]	CONV[2]	CONV[1]	CONV[0]
0000	TRVBG[3]	TRVBG[2]	TRVBG[1]	TRVBG[0]	NONPREV	DIGIT4	PROHI	INIUNIT

C0[7:0], C1[7:0], C2[7:0], C3[7:0], C4[7:0], C5[7:0], C6[7:0], C7[7:0], C8[7:0], C9[7:0], C10[7:0] – division factor bits of the temperature precounter. They depend on used types of thermoresistor R_s and reference resistor R_R .

IVTC3[3:0], IVTC2[3:0], IVTC1[3:0], IVTC0[1:0] – correction factor bits of the temperature counter.

TRFSYS [4:0] – system clock bits.

CONV [2:0] – convergence time set bits.

TRVBG [3:0] –BLD adjustment bits.

NONPREV – previous value backing out bit: «1» – hide, «0» – display.

DIGIT4 –point digit number (decimal part) bit: «1» – 2 digits, «0» – 1 digit

PROHI –°C/°F unit switching disable bit: «1» – unit switching disabled, «0» – unit switching enabled.

INIUNIT – start measurement unit bit: «1» – °C, «0» – °F.



Table 8 – EEPROM data written by chip manufacturer

Address	Data
0000	10000101
0001	10000111
0010	00000000
0011	01110000
0100	11101000
0101	11100000
0110	11011000
0111	11010001
1000	11001001
1001	11000011
1010	10111100
1011	10110110
1100	10110000
1101	10101010
1110	00001010

Selected bits TRVBG[3:0] are used for battery low detector (BLD) adjustment. BLD adjustment is processed by chip manufacturer.



Calibration and adjustment

To process temperature measurement calibration IZ8071 chip should be placed in the package, and contact pads of the chip should be connected to package pins in appropriate way. Thermoresistor R_S , reference resistor R_R , resistor R_X , capacities C_S , C_P and C_{V1} should be connected.

The thermometer sensor should be placed in the thermostat with constant temperature 37,00°C. There is a temperature measurement. The measured values of temperature can be read in BDC format by personal computer via PCB interface, or directly from contact pad by LCD.

It is necessary to set correcting factors for case the measured temperature differs from real.

The correcting factor ΔT is calculated under the formula:

$$\Delta T = 7,0000 + (T_A - T_{MEAS}),$$

T_A – real temperature, °C (usually 37,0 °C),

T_{MEAS} – measured temperature, °C.

The correcting factor in code BDC is writing into EEPROM bits IVTC3 [3:0], IVTC2 [3:0], IVTC1 [3:0], IVTC0 [1:0].

Calibration features:

- Step of calibration 0,0025 °C;
- Range of calibration from 35 to 39 °C;
- Accuracy of installation real temperature
 - 0,005 °C for a range 36,0 ... 38,0 °C;
 - 0,009 °C for ranges 35,0 ... 36,0 °C, and 38,0... 39,0 °C.

Table 9 – Samples of correcting factors for various temperature deviations

Measured temperature, °C	Correcting factor ΔT , decimal and binary				
	Decimal	IVTC3[3:0]	IVTC2[3:0]	IVTC1[3:0]	IVTC0[1:0]
35,7000	8,3000	1000	0011	0000	00
...
36,9100	7,0900	0111	0000	1001	00
...
36,9800	7,0200	0111	0000	0010	00
...
36,9900	7,0100	0111	0000	0001	00
36,9925	7,0075	0111	0000	0000	11
36,9950	7,0050	0111	0000	0000	10
36,9975	7,0025	0111	0000	0000	01
37,0000	7,0000	0111	0000	0000	00
37,0025	6,9975	0110	1001	1001	11
37,0050	6,9950	0110	1001	1001	10
37,0075	6,9925	0110	1001	1001	01
37,0100	6,9900	0110	1001	1001	00
...
37,0200	6,9800	0110	1001	1000	00
...
38,3000	5,7000	0101	0111	0000	00

Such correction provide the least deviations of measured temperature from real in a range of temperatures 32 ...42 °C (89,6 ... 107,5 °F).

Contact pad layout

ICs available for shipment in chip form without orientation loss.
 Weight of IC no more than 0,01

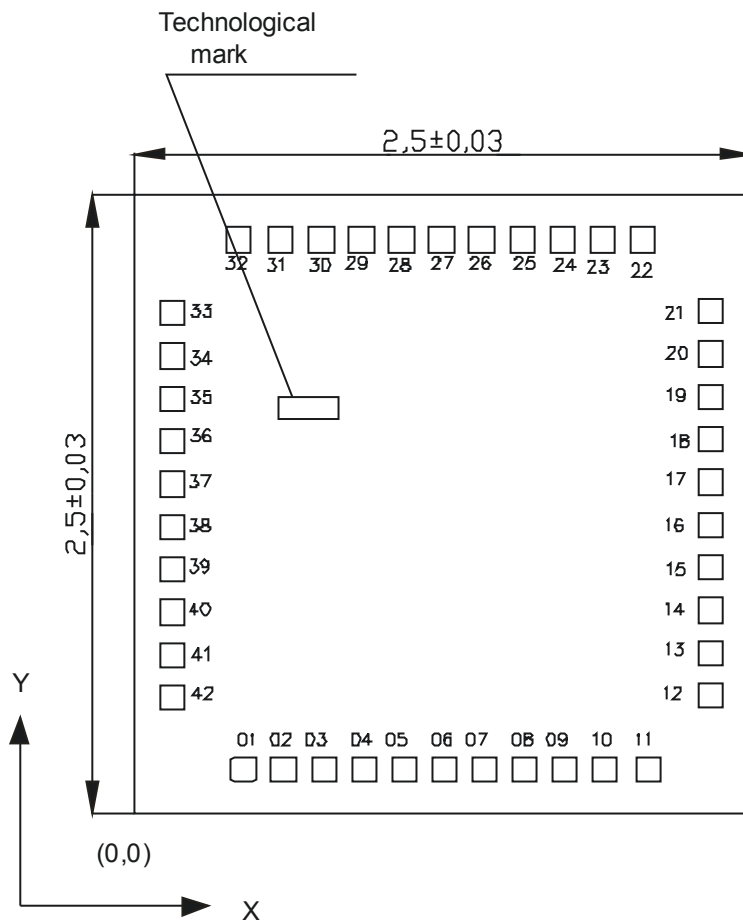

Chip thickness $0,35 \pm 0,02$ mm.
 Technological mark on chip 8071.3 coordinates, mm: $x=0,600$, $y=1,550$.

Fig.12 – Contact pad layout diagram

Table 10 – Contact pads coordinates and dimension

Contact pad number	Symbol	Coordinates (Left bottom corner), mm	
		X	Y
01	V _{DD}	0,127	0,397
02	T1	0,127	0,560
03	T2	0,127	0,723
04	HV	0,127	0,886
05	T4	0,127	1,049
06	RSYS1	0,127	1,211
07	T5	0,127	1,374
08	RSYS2	0,127	1,537
09	T6	0,127	1,700
10	SYSCK	0,127	1,863
11	T7	0,127	2,037
12	SCK	0,429	2,289
13	DATA	0,682	2,289
14	BRESET	0,774	2,289
15	MODE	0,947	2,289
16	SW	1,128	2,289
17	COM3	1,293	2,289
18	COM2	1,466	2,289
19	COM1	1,638	2,289
20	SEG11	1,811	2,289
21	SEG10	1,984	2,289
22	SEG9	2,273	2,014
23	SEG8	2,273	1,852
24	SEG7	2,273	1,689
25	SEG6	2,273	1,526
26	SEG5	2,273	1,363
27	SEG4	2,273	1,200
28	SEG3	2,273	1,038
29	SEG2	2,273	0,875
30	SEG1	2,273	0,712
31	C2	2,273	0,549
32	C1	2,273	0,374
33	V _{DD2}	1,976	0,112
34	BZ1	1,803	0,112
35	BZ2	1,630	0,112
36	VBGR	1,458	0,112
37	T3	1,285	0,112
38	RS	1,112	0,112
39	RF	0,939	0,112
40	SC	0,766	0,112
41	V _{SS}	0,594	0,112
42	TEST	0,421	0,112

Note – Coordinates and size of the contact pads 0,100 x 0,100 mm are given by the layer «Passivation»