

White LED Step-Up Converter

(Functional equivalent of LT1937 Linear Technology Corporation)

Description

The IZ1937 is a step-up DC/DC converter specifically designed to drive white LEDs with a constant current. The device can drive two, three or four LEDs in series from a Li-Ion battery. Series connection of the LEDs provides identical LED currents resulting in uniform brightness and eliminating the need for ballast resistors. The IZ1937 operates at 1.2MHz, allowing the use of tiny external components. The output capacitor can be as small as 0.22uF, saving space and cost versus alternative solutions.

A low 95mV feedback voltage minimizes power loss in the current setting resistor for better efficiency.

The device can be used in mobile phones, PDAs, Handheld Computers, calculators, digital cameras, MP3-players, GPS-receivers.

Features

- Internally determined LED current
- High Efficiency: 84% Typical
- Drives Up to 4 LEDs from a 3.2V Supply
- Drives Up to 6 LEDs from a 5V Supply
- 36V rugged bipolar switch
- Fast 1.2MHz switching frequency
- Uses tiny 1mm Tall Inductors
- Requires only 0.22uF output capacitor

ICs are available for shipment in chip form on unsawn wafers

Tab 1. Contact Pad Description

Contact pad number	Symbol	Description
01	SW	Switch pad (Pin)
02	GND	Common pad (pin)
03	V _{IN}	Input supply pad (pin)
04	$\overline{\text{SHDN}}$	Shutdown pad (pin)
05	GND	Common pad (pin)
06	FB	Feedback pad (pin)

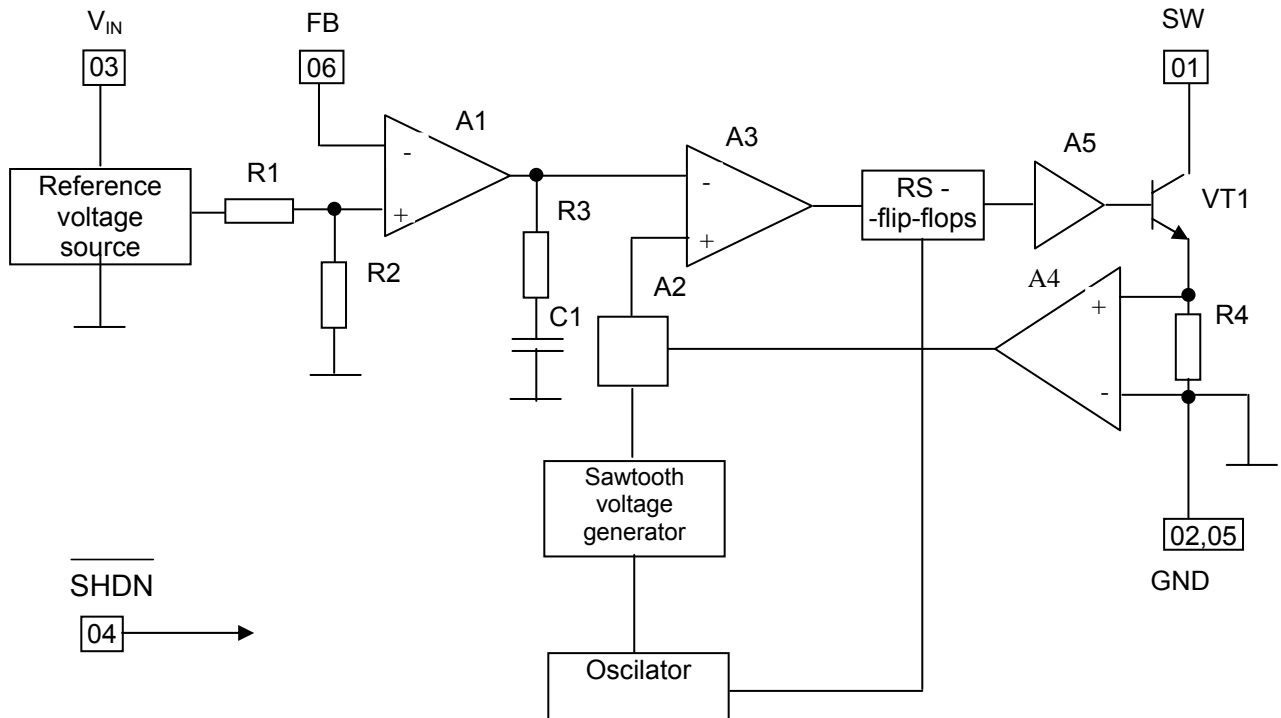

- A1 – error amplifier;
- A2 – addrer;
- A3 – PWM – comprator;
- A4 – comparator;
- A5 –driver;
- C1 – capacitor;
- R1 – R4 – resistor;
- VT1 – transistor

The device contains a switch on/off circuit; output current overruling protection unit, driver-buffer, output switch.

Fig.1 Block Diagram

Table 2 –Absolute maximum ratings

Symbol	Parameter	Absolute maximum ratings		Unit
		Min.	Max.	
U_{IN}	Input voltage	-	10	V
U_{SW}	SW pin Voltage	-	36	V
U_{FB}	FB pin Voltage	-	10	V
U_{SHDN}	SHDN pin Voltage	-	10	V
T_J	Storage Temperature	-	150	°C
T_{stg}	Junction Temperature	-60	150	°C

Table 3 – Recommended operating mode

Symbol	Parameter	Recommended operating mode		Unit
		Min.	Max.	
U_{IN}	Input voltage	2,5	10	V
T_J	Storage Temperature	-	125	°C

Table 4 Electric Parameters

Parameter, unit	Symbol	Value		Testing mode	Ambient temperature, °C
		Min.	Max.		
Minimum input voltage, V	$U_{IN\ MIN}$	$\frac{2,5}{2,5}$	-	$U_{SHDN} = 3,0\ V$	$\frac{25 \pm 10}{-40 \dots +125}$
Maximum input voltage, V	$U_{IN\ MAX}$	-	$\frac{10}{10}$		
Feedback Voltage, mV	U_{FB}	$\frac{86}{76}$	$\frac{104}{114}$	$U_{IN} = 3,0\ V,$ $U_{SHDN} = 3,0\ V,$ $I_{SW} = 100\ mA$ Duty Cycle 66 %	
FB pad Bias Current, nA	I_{FB}	$\frac{10}{10}$	$\frac{100}{150}$	$U_{IN} = 3,0\ V,$ $U_{SHDN} = 3,0\ V$	
Supply Current,	I_Q				
mA		-	$\frac{2,5}{3,75}$	$U_{IN} = 3,0\ V,$ $U_{SHDN} = 3,0\ V$	
µA		-	$\frac{1,0}{2,0}$	$U_{IN} = 3,0\ V,$ $U_{SHDN} = 0\ V$	
Switching Frequency, MHz	f_S	$\frac{0,8}{0,6}$	$\frac{1,6}{1,8}$	$U_{IN} = 3,0\ V,$ $U_{SHDN} = 3,0\ V$	
Maximum Duty Cycle, %	DC_{MAX}	$\frac{85}{80}$	-	$U_{IN} = 3,0\ V,$ $U_{SHDN} = 3,0\ V$	
Switch Leakage Current, µA	I_{LSW}	-	$\frac{5,0}{7,5}$	$U_{IN} = 3,0\ V, U_{SHDN} = 3,0\ V,$ $U_{SW} = 5,0\ V$	

Table 4 Electric Parameters (continued)

Parameter, unit	Symbol	Value		Testing mode	Ambient temperature, °C
		Min.	Max.		
$\overline{\text{SHDN}}$ Voltage High, V	U_{IH}	$\frac{1,5}{1,5}$	-	$U_{IN} = 3,0 \text{ V}$ Note 1	$\frac{25 \pm 10}{-40 \dots +125}$
$\overline{\text{SHDN}}$ Voltage Low, V	U_{IL}	-	$\frac{0,4}{0,4}$	$U_{IN} = 3,0 \text{ V}$ Note 1	

Notes

1 During U_{IH} & U_{IL} measurements threshold voltage is tested, which has to be within range from 0,4 to 1,5 V (see fig. 2).

2 Symbol descriptions :

- $U_{\overline{\text{SHDN}}}$ - Shutdown pad voltage (contact pad 04);
- U_{FB} – Feedback Voltage pad voltage (contact pad 06);
- U_{SW} – Switch pad voltage (contact pad 01);
- I_{SW} – Switch pad current (contact pad 01).

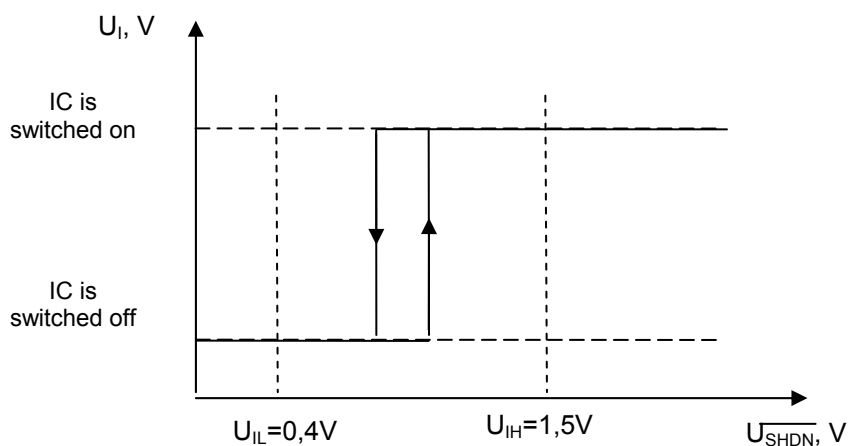

Fig.2 Switching on/off diagramm

Table 5 –Typical Electric Parameters

Symbol	Parameter, unit	Testing mode	Typ.value	Unit
I_{CL}	Output transistor current limit	$U_{IN} = 3,0 \text{ V}, U_{\overline{SHDN}} = 3,0 \text{ V}$	320	mA
U_{CESAT}	Output transistor saturation voltage	$U_{IN} = 3,0 \text{ V}, U_{\overline{SHDN}} = 3,0 \text{ V}, I_{SW} = 250 \text{ mA}$	350	mV
I_{SHDN}	\overline{SHDN} pad (pin) bias current	$U_{IN} = 3,0 \text{ V}, U_{\overline{SHDN}} = 3,0 \text{ V}$	65	uA

OPERATION DESCRIPTION

The IZ1937 consist of following units: voltage switch on/off circuit, sawtooth generator, rectangular pulse generator PWM –comparator RS-latch, error amplifier, output buffer, output switch, current-limit circuit for output switch.

The IZ1937 uses a constant frequency, current mode control scheme to provide excellent line and load regulation.

At the start of each oscillator cycle, signal from oscillator applied to S-pin of the RS-latch, the latch output high level voltage is set. This voltage through buffer turns on the power switch (transistor VT1). A voltage proportional to the switch current is added to a stabilizing sawtooth voltage and the resulting sum is applied to the positive terminal of the PWM comparator A3. When this voltage exceeds the level at the negative input of A3, the SR latch is reset turning off the power switch VT1. The level at the negative input of A3 is set by the error amplifier A1, and is simply an amplified version of the difference between the feedback voltage and the reference voltage of 95mV. In this way, the error amplifier A1 controls the peak current level to keep the output in regulation. If the error amplifier's output increases, more current is delivered to the output; if it decreases, less current is delivered.

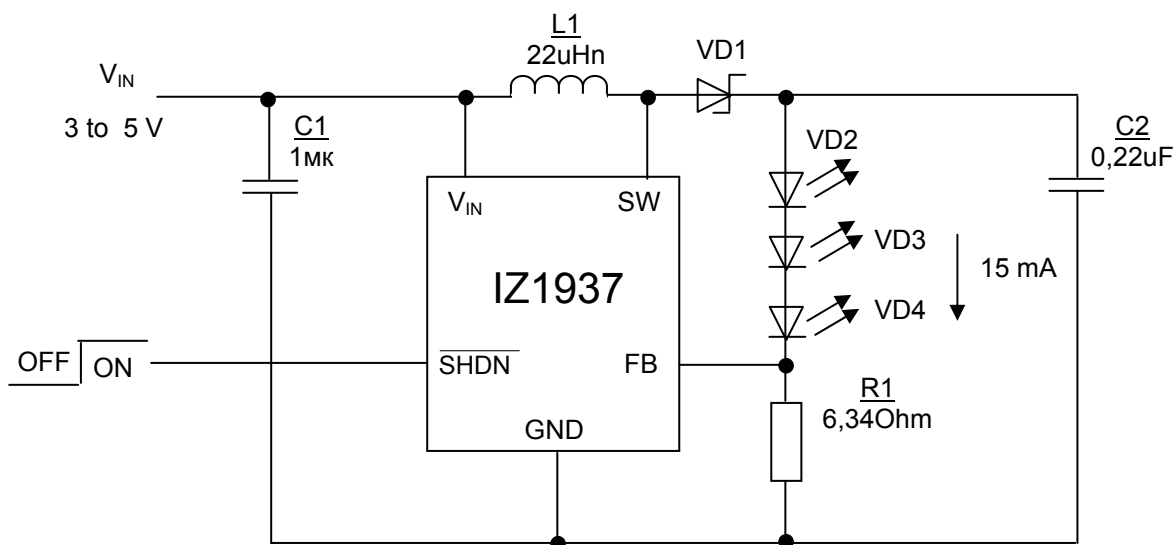

VD1 – Schottki diode;
 VD2 – VD4 - diodes

Fig. 3 – Typical application diagramm (3 white LED driver supplied by Li-ion battery)

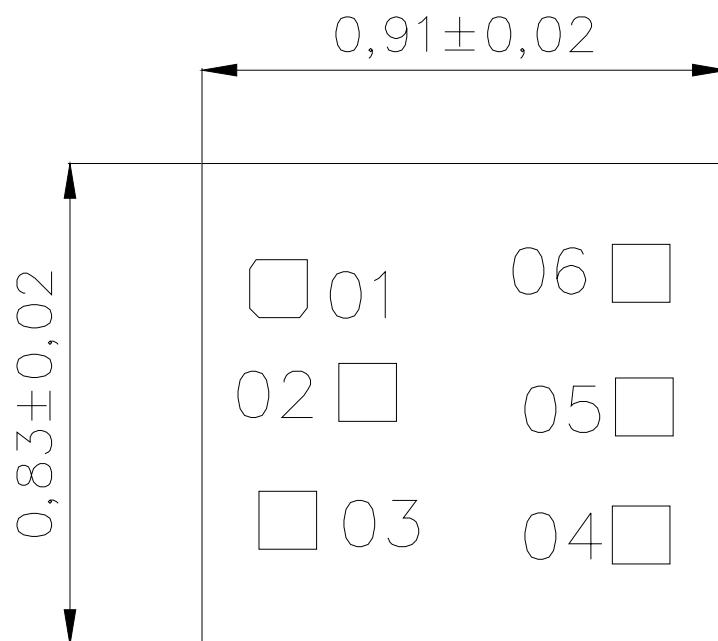

Fig. 4– Chip diagramm

Table 5 – Contact pads coordinates

Contact pad number	Coordinates (ref. left bottom corner), mm	
	X	Y
01	0.0825	0.564
02	0.237	0.385
03	0.0985	0.1645
04	0.711	0.139
05	0.7165	0.360
06	0.711	0.5905

Notes– Size of contact pads 100×100 μm by the layer «passivation». Coordinates of the contact pads are indicated by the layer «passivation»