

**ICs of voltage regulator 5V/400mA, 8.5V/400mA, 10V/400mA  
and adjustable with low drop voltage  
(FUNCTIONAL EQUIVALENT OF TLE4276G INFINEON)**

ILE4276VXXG, ILE4276VXXS - are integrated circuits of voltage regulator

- ILE4276V50G, ILE4276V50S – 5,0 V/400 mA
- ILE4276V85G, ILE4276V85S – 8,5V/400 mA;
- ILE4276V10G, ILE4276V10S – 10V/400 mA;
- ILE4276VG, ILE4276VS – adjustable from 2,5 to 20 V.

5V/400 mA with low-drop voltage. ICs realized in 5-pin plastic packages ILE4250G - P-TO263-5-1, ILE4250S – P-TO220-5-12.

ICs are purposed to supply DC voltages 5V, 8,5V, 10V and adjustable from 2,5 to 20 V with drop voltage less 0,5V, with load current 250 mA and low consumption current. ICs are used in power supply units of electronic devices, including automotive electronics. ICs are tolerant to over voltage of both polarities (positive & negative), provide internal current limitation and output voltage thermal shutdown.

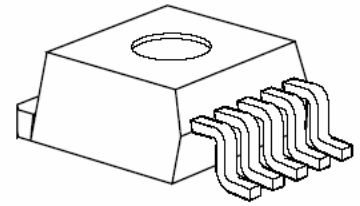

**Fig. 1 – View of IC in P-TO263-5-1 package**

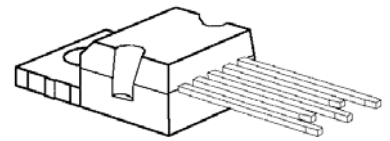
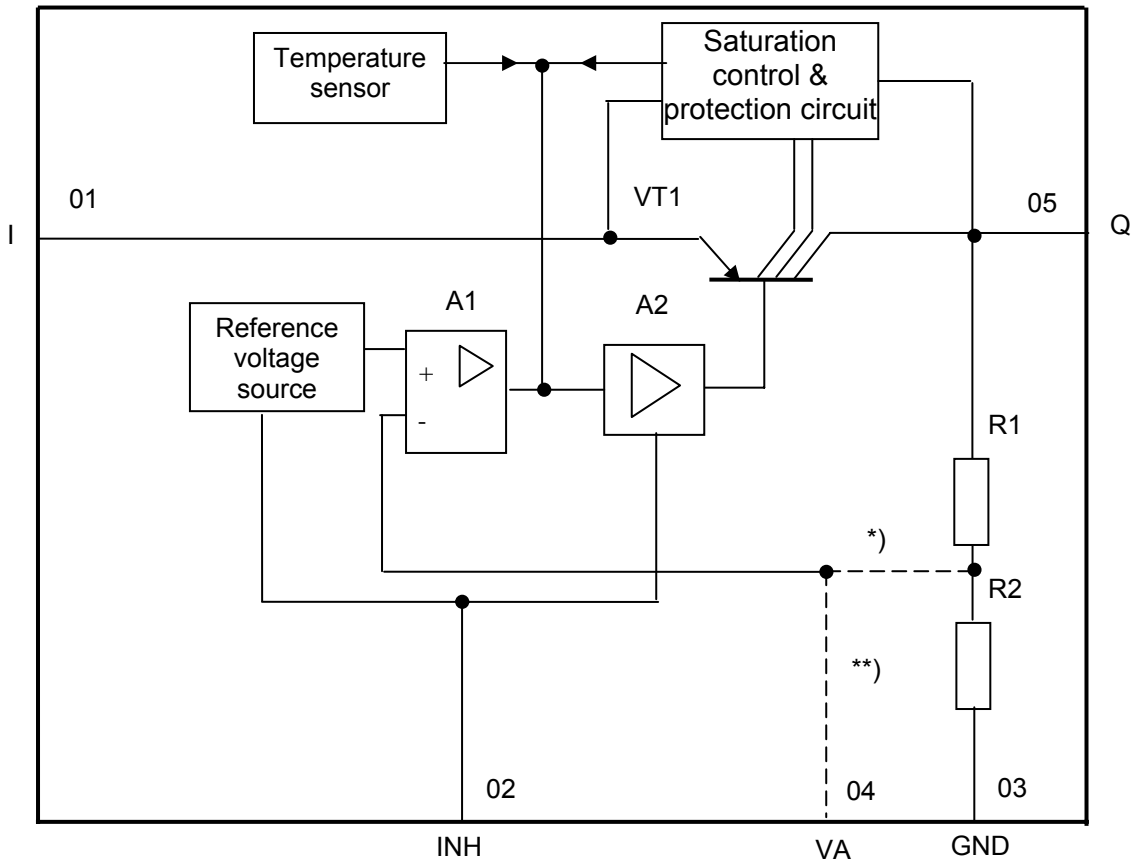

**Fig. 2 – View of IC in P-TO220-5-12 package**

**Main features**

- Accuracy of the output voltage  $\pm 4\%$ ;
- Low-drop voltage ;
- Low consumption current;
- Built-in overheating protection;
- Reverse polarity proof;
- Wide junction temperature range -40 ... +150°C;
- Suitable for use in automotive electronics;
- Inhibit input.

Permissible value of ESD potential 1000V



A1 – control amplifier;  
 A2 – buffer;  
 R1, R2 –resistors;  
 VT1 - transistor

\* For ICs ILE4276V10G, ILE4276V10S, ILE4276V50G, ILE4276V50S, ILE4276V85G, ILE4276V85S.

\*\* For ICs ILE4276VG, ILE4276VS.

**Fig. 3 – Electric block diagram**

**Table 1 Pins description**

Chip pad number	Package pin number	Symbol	Function
01	01	I	Input
02	02	INH	Inhibit input
03	03	GND	Common pin (Ground)
04	04	NC	For ILE4276V85G, ILE4276V50G, ILE4276V10G pin is not used
		VA	Adjustment input (for ILE4276VG)
05	05	Q	Output

**Table 2 Absolute Maximum Ratings**

Symbol	Parameters	Norm		Unit
		min.	max.	
T <sub>J</sub>	Junction temperature	-40*	150	°C
T <sub>stg</sub>	Storage temperature	-50	150	°C
U <sub>I</sub>	Input voltage I ILE4276V50G, ILE4276V50S ILE4276V85G, ILE4276V85S ILE4276V10G, ILE4276V10S ILE4276VG, ILE4276VS (at U <sub>Q</sub> < 4 V)	-42	45	V
U <sub>INH</sub>	Inhibit input voltage	-42**	45**	V
I <sub>GND</sub>	Ground pin current	-	100	mA
U <sub>Q</sub>	Output voltage ILE4276V50G, ILE4276V50S ILE4276V85G, ILE4276V85S ILE4276V10G, ILE4276V10S ILE4276VG, ILE4276VS	-1,0**	40**	V
U <sub>VA</sub>	Adjustment input voltage ILE4276VG, ILE4276VS	-0,3**	10**	V
<p>* Ambient temperature is indicated. ** Voltage is not applied to input I</p>				

**Table 3 – Recommended operation modes**

Symbol	Parameter	Norm		Unit
		Min.	Max.	
T <sub>J</sub>	Junction temperature	-40*	150	°C
U <sub>I</sub>	Input voltage ILE4276V50G, ILE4276V50S ILE4276V85G, ILE4276V85S ILE4276V10G, ILE4276V10S ILE4276VG, ILE4276VS (при U <sub>Q</sub> < 4 В)	5,7 9,34 10,9 4,5	40 40 40 40	V
U <sub>Q</sub>	Output voltage ILE4276V50G, ILE4276V50S ILE4276V85G, ILE4276V85S ILE4276V10G, ILE4276V10S ILE4276VG, ILE4276VS	4,8 8,16 9,6 2,4	5,2 8,84 10,4 20	V
U <sub>VA</sub>	Adjustment input voltage ILE4276VG, ILE4276VS	2,4**	2,6**	V

**Table 3 continued**

Note:

Maximum power  $P_{tot}, W$ , dissipated by IC at ambient temperature  $T_A$ , is calculated by formula:

$$P_{tot} = (150 - T_A) / R_{th\ j-a} , \quad (1)$$

150 – maximum permissible operating junction temperature, °C.

$R_{th\ j-a}$  - thermal resistance junction ambient (for IC without heat sink), °C /W,  
for ILE4276VG, ILE4276V50G, ILE4276V85G, ILE4276V10G without heat sink  $R_{th\ ja}$  is equal 80 °C /W

for ILE4276VS, ILE4276V50S, ILE4276V85S, ILE4276V10S ILE4275S without heat sink  $R_{th\ ja}$  is equal 65 °C /W

for IC with heat sink  $R_{th\ ja}$  is calculated by formula

$$R_{th\ j-a} = R_{th\ j-c} + R_{th\ c-a} , \quad (2)$$

$R_{th\ j-c}$  - thermal resistance junction case, °C /W.  $R_{th\ jc} = 4$  °C/W.

Thermal resistance case-ambient  $R_{th\ c-a}$  is determined by heat sink design and is selected by IC customer.

Application circuit and heat sink and ambient temperature have to provide junction temperature not more  $T_J \leq 150$  °C.

\* Ambient temperature is indicated.

**Table 4 – Electric parameters**  
 ( $U_I = 13,5 \text{ V}$ ,  $-40 \text{ °C} \leq T_J \leq 150 \text{ °C}$  unless otherwise specified)

Symbol	Parameter	Mode of measurement	Norm		Unit
			Min.	Max.	
$U_Q$	Output voltage	For ILE4276V50G, ILE4276V50S			V
		$6 \text{ V} \leq U_I \leq 28 \text{ V}$ $-5 \text{ mA} \leq I_Q \leq -400 \text{ mA}$	4,8	5,2	
		$6 \text{ V} \leq U_I \leq 40 \text{ V}$ $-5 \text{ mA} \leq I_Q \leq -200 \text{ mA}$	4,8	5,2	
		For ILE4276V85G, ILE4276V85S			
		$9.5 \text{ V} \leq U_I \leq 28 \text{ V}$ $-5 \text{ mA} \leq I_Q \leq -400 \text{ mA}$	8,16	8,84	
		$9.5 \text{ V} \leq U_I \leq 40 \text{ V}$ $-5 \text{ mA} \leq I_Q \leq -200 \text{ mA}$	8,16	8,84	
		For ILE4276V10G, ILE4276V10S			
		$11 \text{ V} \leq U_I \leq 28 \text{ V}$ $-5 \text{ mA} \leq I_Q \leq -400 \text{ mA}$	9,6	10,4	
$\Delta U_Q$	Output voltage accuracy	For ILE4276VG, ILE4276VS $R_2 < 50 \text{ k}\Omega$ , $(U_Q + 1) \text{ V} \leq U_I \leq 40 \text{ V}$ , $U_I > 4,5 \text{ V}$ , $-5 \text{ mA} \leq I_Q \leq -400 \text{ mA}$			%
		-4	4		
$I_{Qmax}$	Maximum output current	Note 2	400	1100	mA
$I_q$	Consumption current $I_q = I_I - I_Q$	$U_{INH} = 0 \text{ V}$ , $T_J \leq 100 \text{ °C}$	-	0,01	mA
		$I_Q = -1 \text{ mA}$	-	0,22	
		$I_Q = -250 \text{ mA}$	-	10	
		$I_Q = -400 \text{ mA}$	-	25	
$U_{dr}$	Drop voltage $U_{dr} = U_I - U_Q$	$I_Q = -250 \text{ mA}$ , Note 2 For ILE4276VG, ILE4276VS: $U_I > 4,5 \text{ V}$	-	0,5	V
$\Delta U_{Q(I)}$	Load current regulation of output voltage	$-5 \text{ mA} \leq I_Q \leq -400 \text{ mA}$	-	0,7	%
$\Delta U_{Q(U)}$	Supply (input) voltage regulation of output voltage	$12 \text{ V} \leq U_I \leq 32 \text{ V}$ $I_Q = -5 \text{ mA}$	-	0,5	

Table 4 continued

Symbol	Parameter	Mode of measurement	Norm		Unit
			Min.	Max.	
Inhibit input parameters					
$U_{INH,on}$	Inhibit on voltage	$U_Q \geq 4,9 \text{ V}$	-	3,5	V
$U_{INH,off}$	Inhibit off voltage	$U_Q \leq 0,1 \text{ V}$	0,5	-	V
$I_{INH}$	Inhibit input current	$U_{INH} = 5 \text{ V}$	5	20	$\mu\text{A}$
<p><b>Notes</b></p> <p>1. Measurement of electric parameters is processed with connected input capacities <math>C_{I1} = 100 \mu\text{F}</math>, <math>C_{I2} = 100 \text{ nF}</math> and output capacity <math>C_Q = 22 \mu\text{F}</math>.</p> <p>2. Drop voltage <math>U_{dr} = U_I - U_Q</math> is measured, when the output voltage <math>U_Q</math> has dropped 100mV from the nominal value obtained at <math>U_I = 13.5 \text{ V}</math>.</p> <p style="text-align: center;">_____</p> <p>* Ambient temperature is indicated.</p>					

**Table 5 – Typical electric parameters**  
 ( $U_I = 13,5 \text{ V}$ ,  $-40 \text{ }^\circ\text{C} \leq T_J \leq 150 \text{ }^\circ\text{C}$  unless otherwise specified)

Symbol	Parameter	Mode of measurement	Typical value	Unit
PSRR	Ripple rejection ratio	$f_r = 100 \text{ Hz}$ , $I_Q = -100 \text{ mA}$ $U_r = 0,5^{**} \text{ V (p - p)}$	54	dB
$dU_Q/dT$	Temperature factor of output voltage	-	0,01	$\text{mV}/^\circ\text{C}$
<p style="text-align: center;">_____</p> <p>* Ambient temperature is indicated.</p> <p>** It is permitted to measure at <math>U_{r(p-p)} = 3 \text{ V}</math>, but for that PSRR norm to be revised</p>				

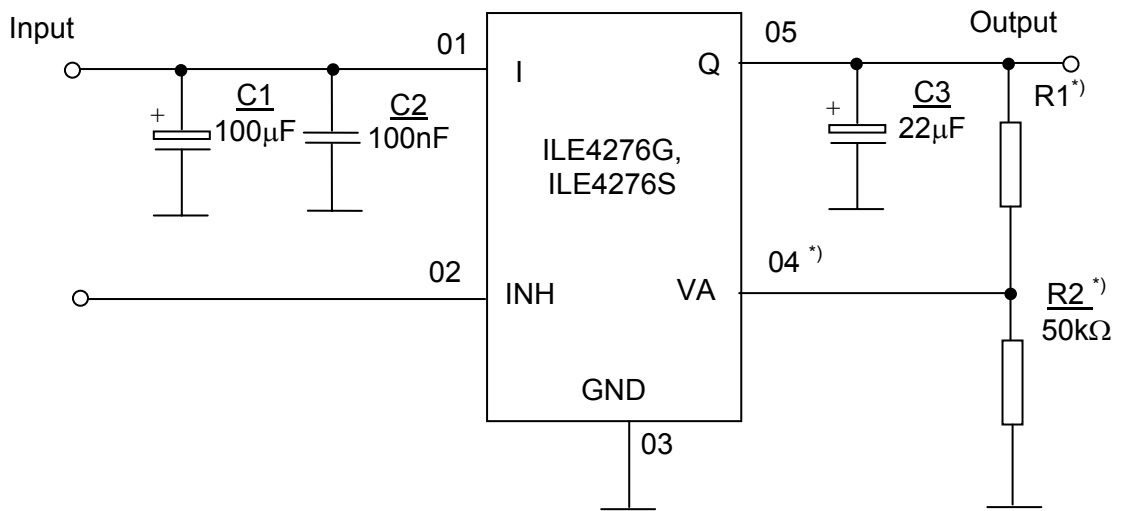

R1, R2 - resistors

\* For ILE4276VG

**Fig 4 – Typical application diagram**

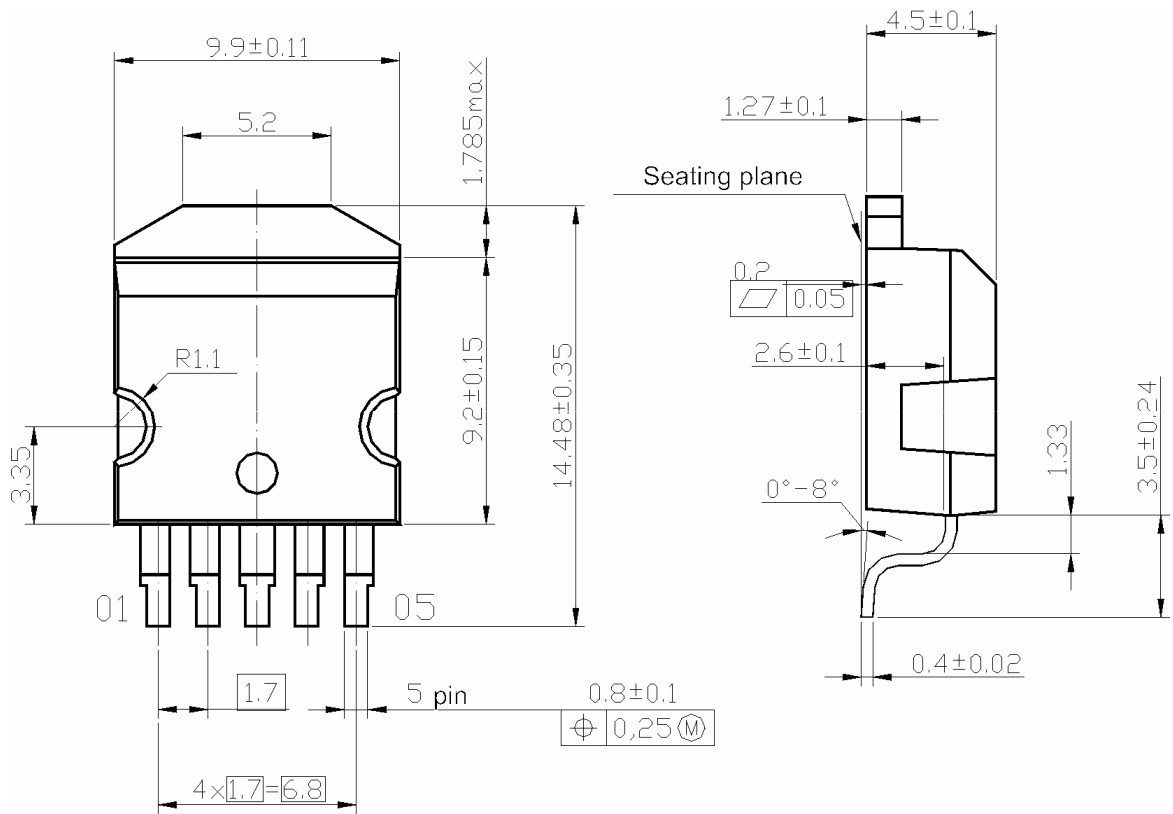

Fig. 5 – P-TO263-5-1 package outline



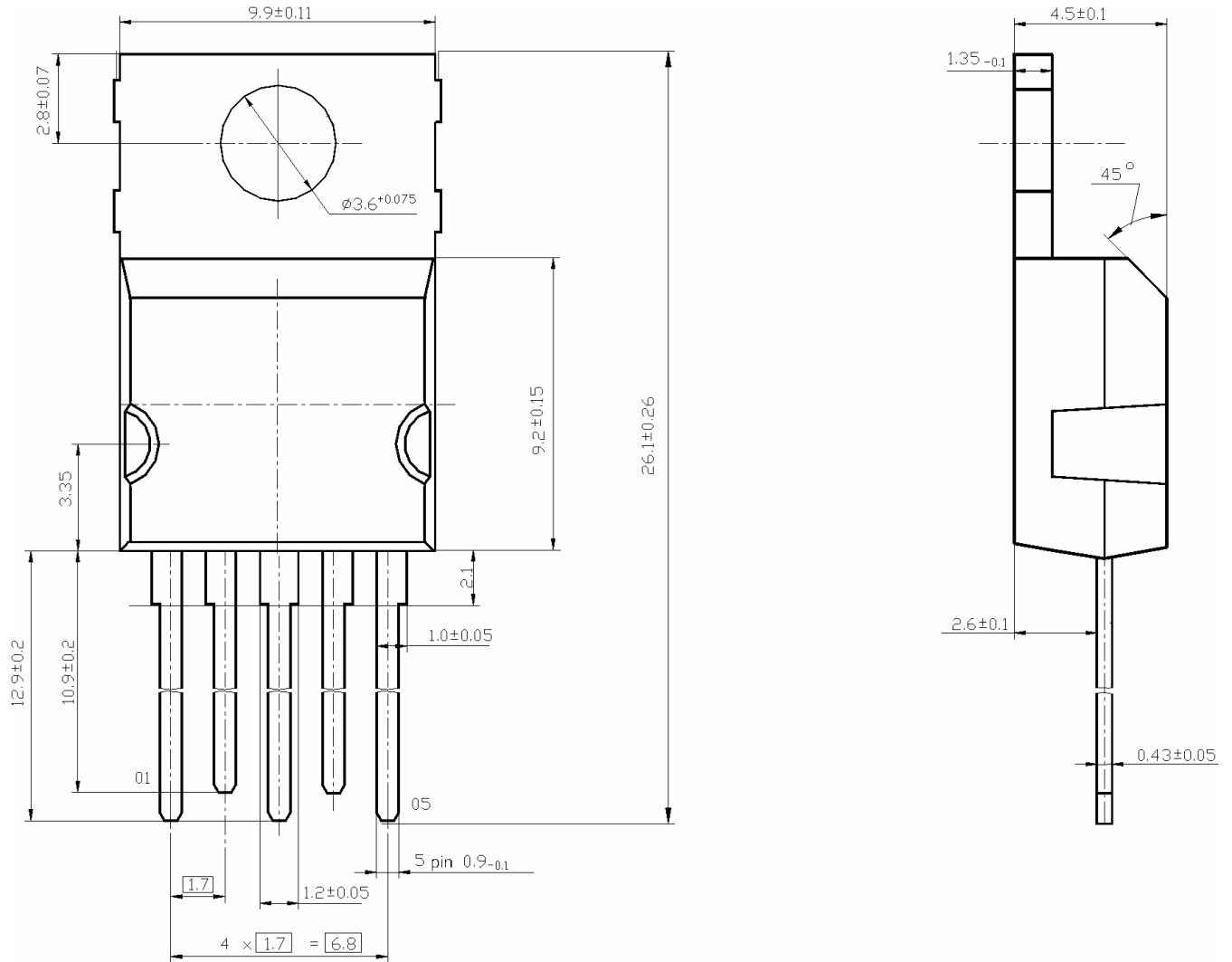
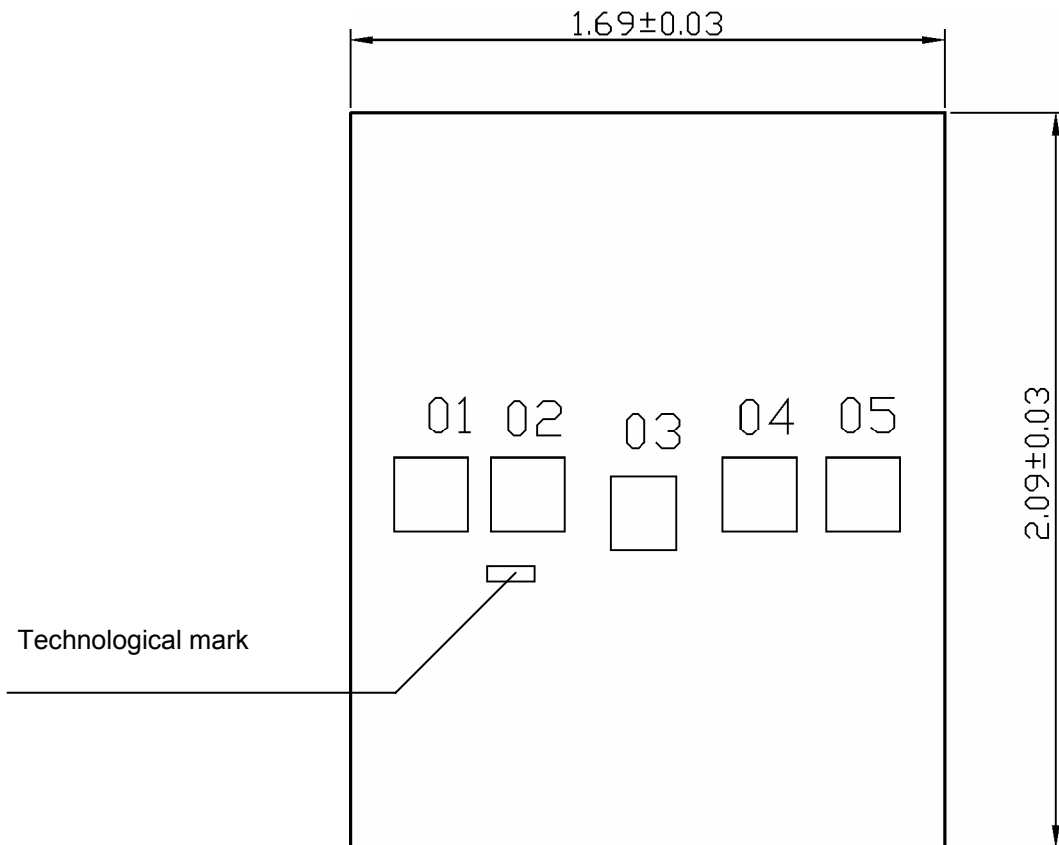

Fig. 6 – P-TO220-5-12 package outline



Contact pad coordinates are indicated in the table 5.

Technological mark on chip has coordinates, mm: left bottom corner

$x = 0,390$  ,  $y = 0,810$

Chip thickness is  $0,35 \pm 0,02$ .

**Fig. 7– Chip outline drawing**

**Table 5 Contact pad location table**

Contact pad number	Coordinates (Left bottom corner), mm	
	X	Y
01	0,1235	0,8995
02	0,3995	0,8995
03	0,7405	0,846
04	1,058	0,8995
05	1,3535	0,8995

Notes

- Coordinates and size of the contact pads are given by the layer «Passivation»
- Sizes of contact pads are  
pads 01;02;04;05 - 0,210 x 0,210 mm,  
pad 03 - 0,186 x 0,210 mm.
- Bevel of two corners of the first contact pad is  $(24 \pm 2) \mu\text{m}$

**Table 6 Technological marks**

IC marking	Technological mark
ILE4276VG, ILE4276VS	4276V
ILE4276V50G, ILE4276V50S	4276V50
ILE4276V85G, ILE4276V85S	4276V85
ILE4276V10G, ILE4276V10S	4276V10

